

24

23

22

21

20

19

18

17

REVISIONS				
ZONE	REV	DESCRIPTION	DATE	APPROVED
D		SEE SHEET 1		

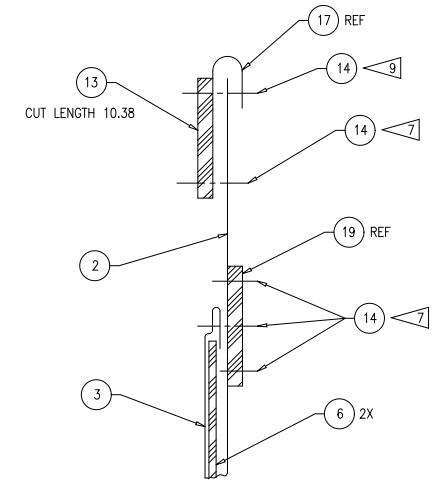
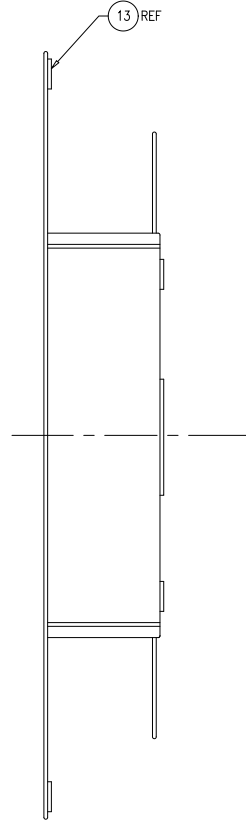
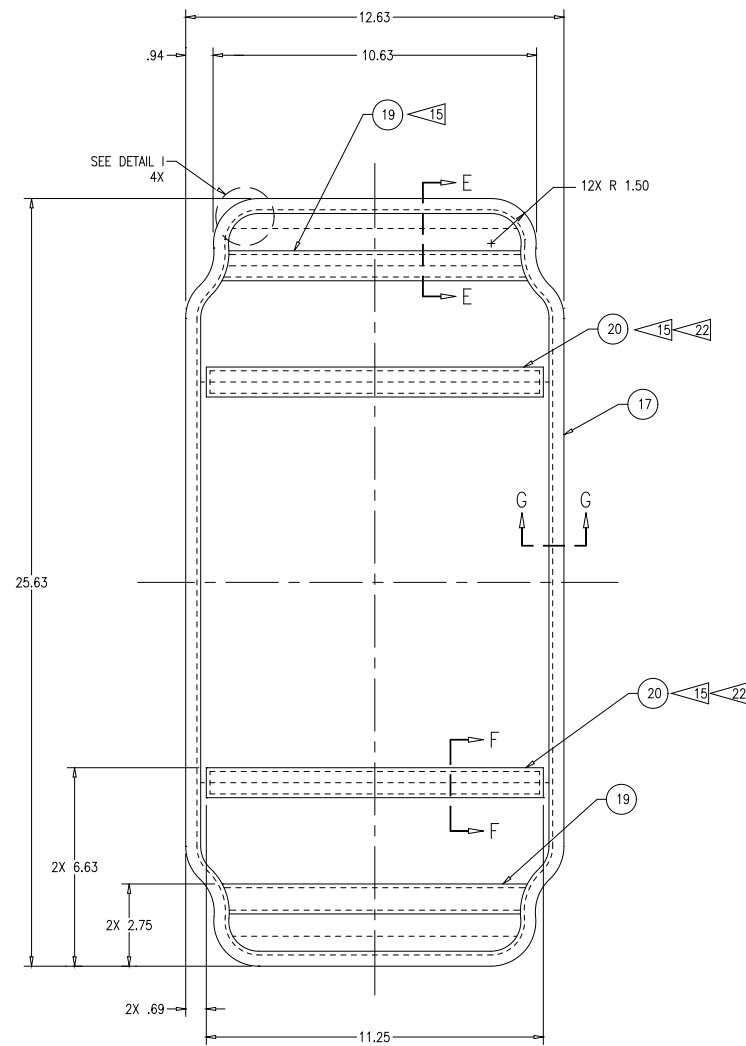

SECTION E-E
SCALE: 2/1
2X

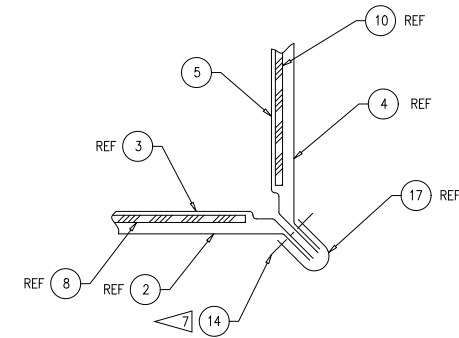
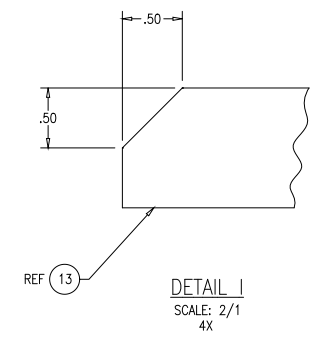

SECTION G-G
SCALE: 2/1
2X

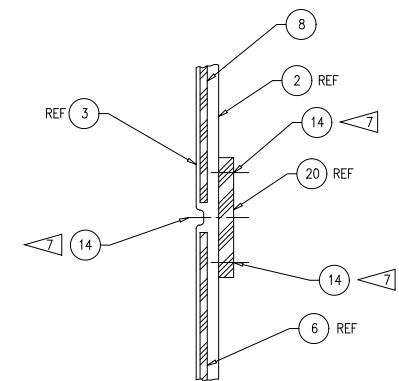

SECTION F-F
SCALE: 2/1
2X

THIRD ANGLE PROJECTION

National Library Service
for the Blind and
Physically Handicapped
The Library of Congress
DRAWN: SCALE: 97-10-02
CHECKED: RBW/LY 97-10-21
SEE DWG NO.: LC642
SHEET 3 OF 5

24

23

22

21

20

19

18

17

32

31

30

29

28

27

26

25

ZONE		REV	DESCRIPTION	DATE	APPROVED
D			SEE SHEET 1		

H
G
F
E
D
C
B
A

H
G
F
E
D
C
B
A

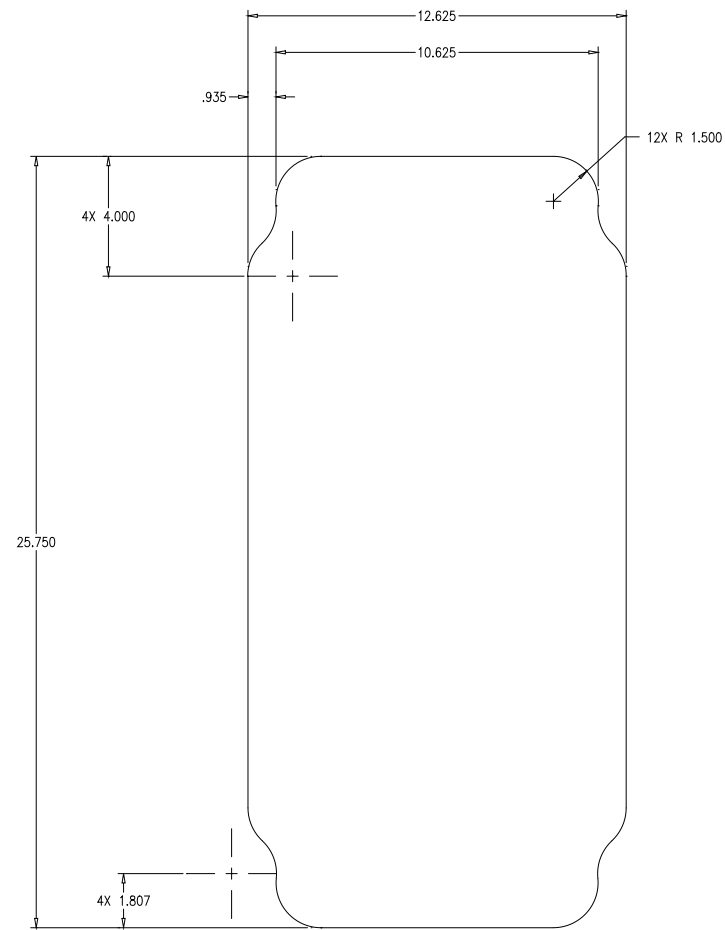

② BACK BODY
CUT WITH DULL SIDE UP
10

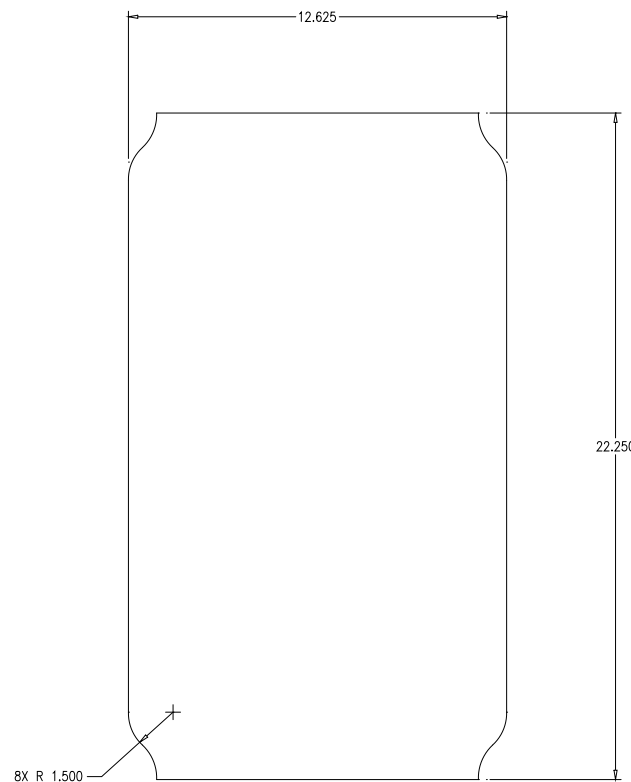

③ BACK LINER
CUT WITH DULL SIDE UP
11

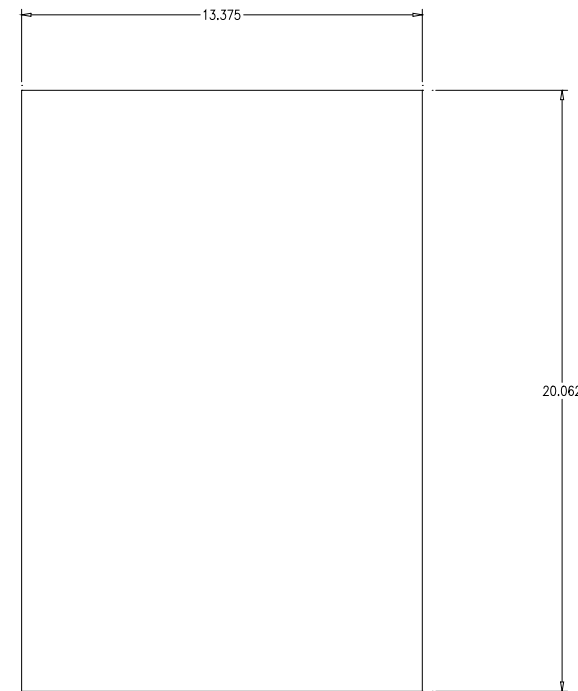

④ FRONT BODY
CUT WITH DULL SIDE UP
10

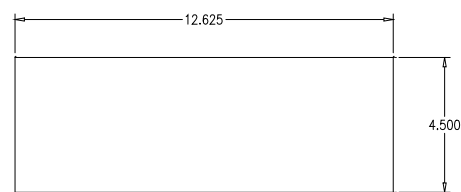

① FLAP, OUTSIDE
CUT WITH DULL SIDE UP
10
2X

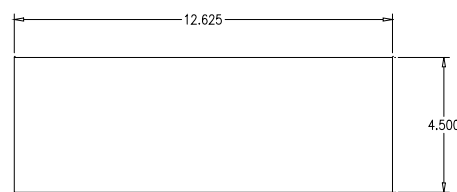

⑪ FLAP LINER
CUT WITH DULL SIDE UP
11
2X

THIRD ANGLE PROJECTION

National Library Service
for the Blind and
Physically Handicapped
The Library of Congress

SEE DWG NO.	LC642	REV	D
DRAWN	SCALE	97-10-02	
CHECKED	R.B.V.L.Y.	97-10-21	SCALE 1/2
SHEET 4 OF 5		UNIT WT.	

32

31

30

29

28

27

26

25

40

39

38

37

36

35

34

33

H
G
F
E
D
C
B
A

ZONE		REV	DESCRIPTION	DATE	APPROVED
D			SEE SHEET 1		

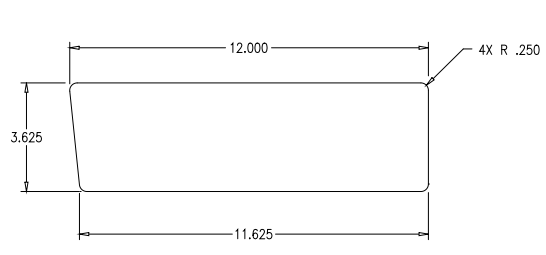

⑦ INSERT, FLAP
 5 18
 2X

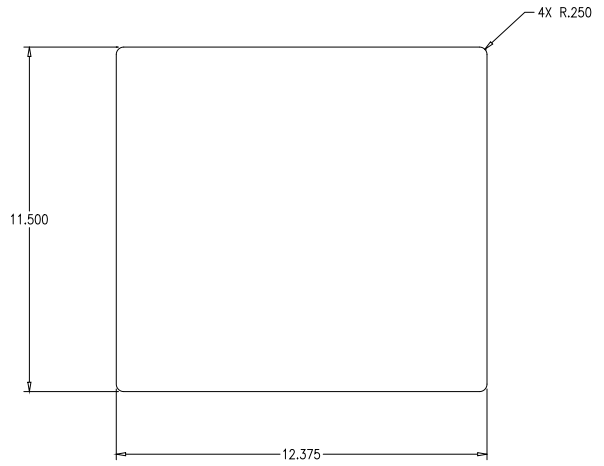

⑨ INSERT, FRONT
 5 18

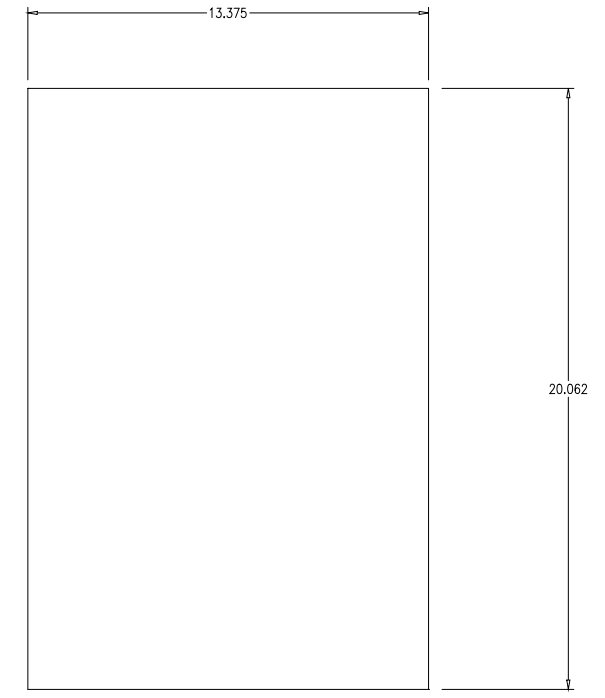

⑤ FRONT LINER
 CUT WITH DULL SIDE UP
 11

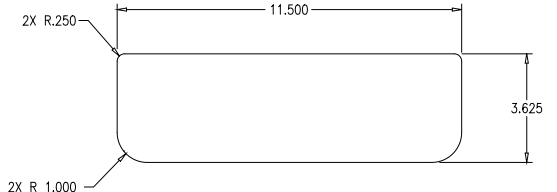

⑥ INSERT, BODY END
 5 18
 2X

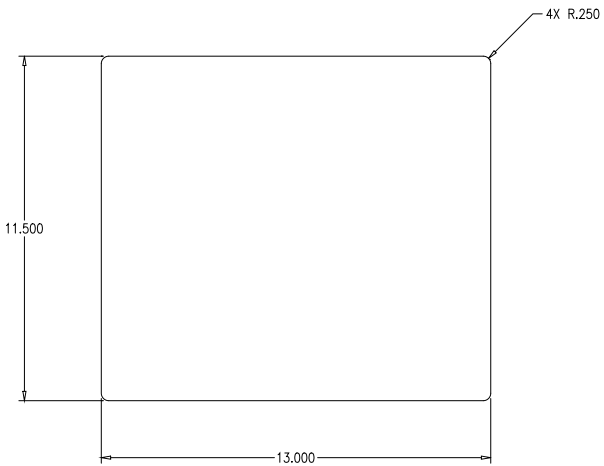

⑧ INSERT, BACK
 5 18

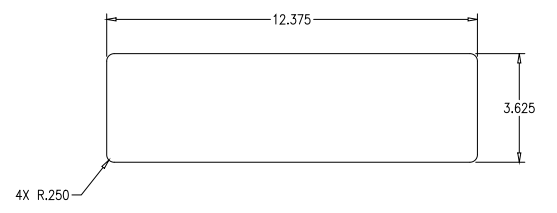

⑩ INSERT, SIDE
 5 18
 2X

THIRD ANGLE PROJECTION

National Library Service
 for the Blind and
 Physically Handicapped
 The Library of Congress

DATE	97-10-02	SCALE	1/2	UNF. NO.	LC642	REV	D
DRAWN	R.BAYLY	CHECKED	R.BAYLY	SHEET	5 OF 5		

40

39

38

37

36

35

34

33